

READ THIS FIRST

Creo® Elements/Direct® 20.0

Important Installation and Usage Information

Directory of Online Information

| | |
|---|---|
| Platform Support | http://www.ptc.com/partners/hardware/current/support.htm |
| Compatibility Matrix and Software Configuration Notes | http://www.ptc.com/appserver/cs/doc/refdoc.jsp |
| PTC Technical Support and the Knowledge Base. | https://www.ptc.com/appserver/cs/portal/ |
| Reference Documents | http://www.ptc.com/appserver/cs/doc/refdoc.jsp |

Note: This document is available only in English.

Creating channels with the new Spline Channel Editor

The new Spline Channel Editor offers Cabling users powerful commands to create and modify channels consisting of spline edges only. Not only a more realistic real-life model, spline edges bring many advantages with them.

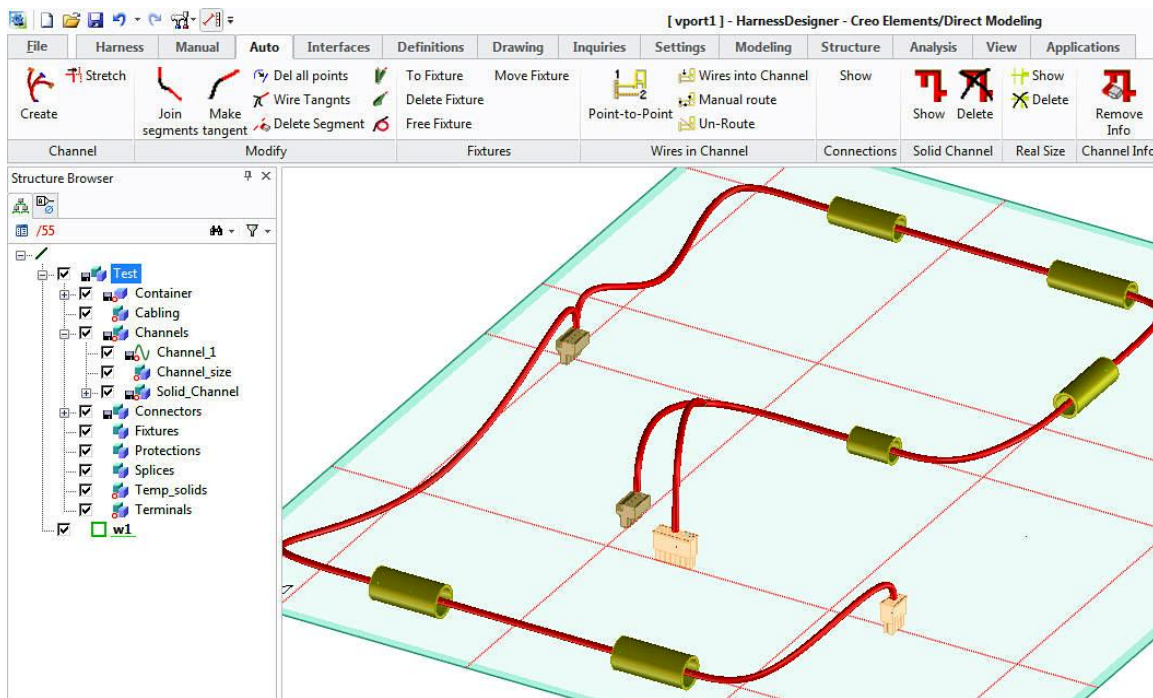

- You can push and pull spline edges without breaking connectivity.
- Spline edges can take almost any form within a single segment.
- Spline edges can be tangentially connected at branch points.
- Spline edges can be adjusted in length easily without adding additional geometry.
- You can delete spline edges with one selection.
- You can push spline edges into guides.

Even though you are allowed to mix spline edges and 'connected 2D geometry' in your channel part, to benefit from the advantages, we recommend from now on to use only splines as channel edges.

Note: Each channel segment should consist of only one single spline edge. More than one spline per edge – even tangentially connected – is not recommended for future compatibility.

Using the Spline Channel Editor

To start **Spline Channel Editor**, click **Auto** and then, in the **Channel** group, click **Create**.

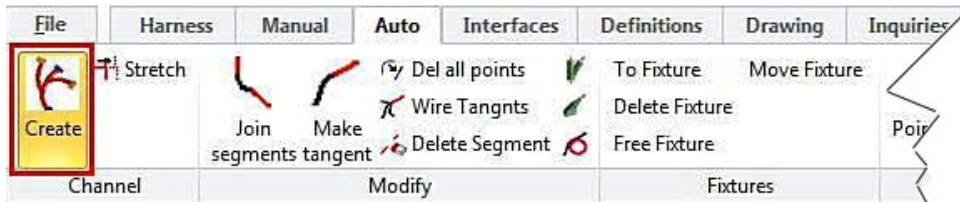

The **Spline Channel Editor** opens. Spline Channel Editor has six tabs.

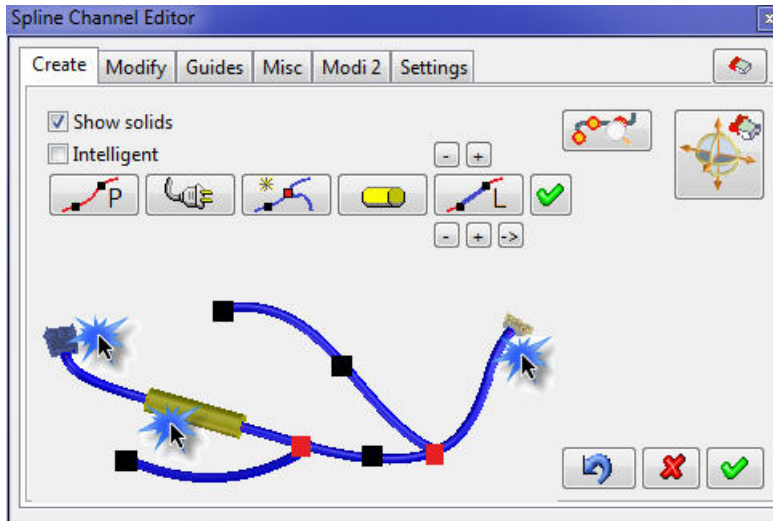

Create Tab

The **Create** tab contains commands to create new channel edges.

Point to Point—Creates a channel segment going through selected points.

1. Click .
2. Specify the first point.

Note: It is not possible to select a point in the space. If you need to specify a point in the space, first select a point on a workplane or on a 3D object. The 3D CoPilot will be visible; use the pole star to drag the point into empty space.
3. Keep specifying further points.
4. Click OK  when you are finished.



If you want to select several points in a row in the air, you can use the 'Lock Point Icon'. Once you enter first point of a segment and pole star is visible, the lock icon will be visible under the 'Point to Point' icon.

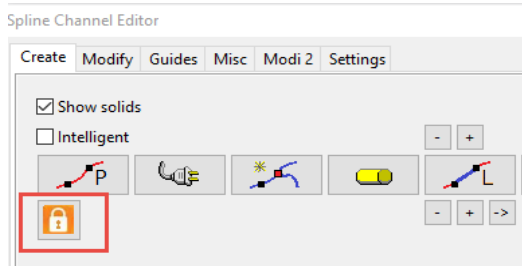

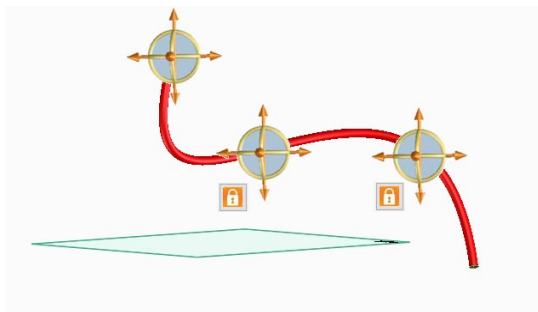

Move 3D CoPilot to the next location and press the lock icon. This point is then taken as next point and user can move the CoPilot to the next point.



From/To Connector—Starts or terminates a channel segment at a connector or terminal.

A device can only be placed at the beginning or at the end of a channel edge. With this option you can either start the edge from a device or terminate the edge with a device. When you select a connector, Cabling automatically calculates a connection point in front of the connector as the next edge point. In case the edge has already been started – since a connector can only be at the end of the edge – the edge will be also automatically terminated.

To create channel from connector to connector,

1. Load two connectors from the Cabling Demo Library into work space.
2. Click .
3. Select the first connector in the viewport.
4. Click  again and select second connector.
5. Click OK .

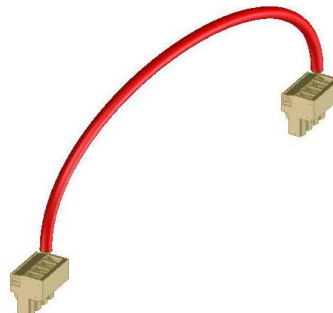



Note: The distance of the edge end point to the connector is a user definable setting (SC_CHANNEL_TO_DEVICE_DIST). It defaults to 10 mm.

Insert Branch—Creates a new branch on an existing segment.

This option must be used when you want to add a branch into a channel segment. Branch points on channel edges must split the edge into two halves, otherwise automatic path calculation will not consider the branching. With the split channel option, Cabling will ask you to select a point on an existing edge. This point will not only be used as spline start point but Cabling will also split the underlying edge automatically.

To insert a branch in the middle of a channel segment,

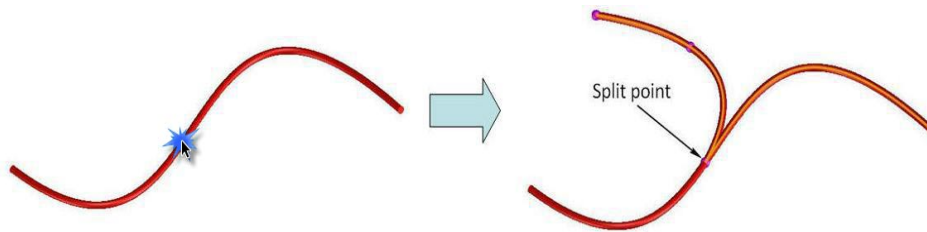

1. Click .
2. Specify a point on an existing channel edge.
3. Continue specifying next points or click OK  to finish.

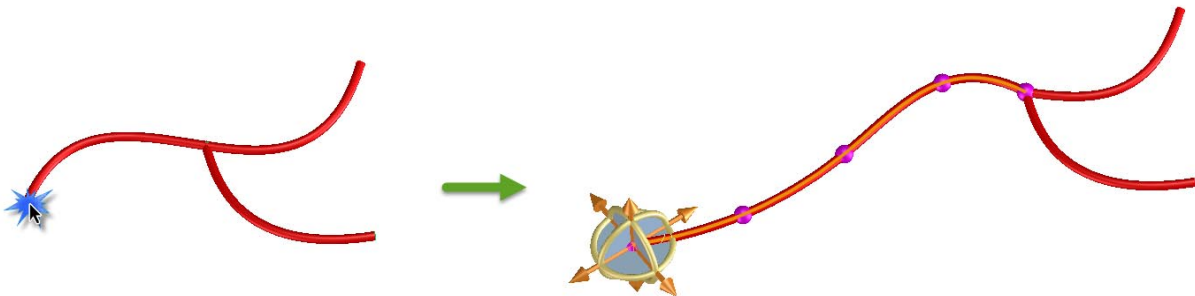

Note: If you select an end point of a spline as '*Insert Branch*' point, since you cannot split the edge there, Cabling assumes that you want to continue to add additional points to this edge and asks for confirmation.



To insert a branch to the end of a segment in the middle of a channel segment,

1. Click .
2. Specify a free end point on an existing channel edge.
3. Confirm the selection.
4. Continue specifying next points or click OK  to finish.

Through guides—Routes the active segment through a guide. Guides are special parts to lead the spline edge through points with tangent directions.

Note: Since edges are 'going through' guides you cannot start or end an edge at a guide.

There are two different types of guides:





- Physical objects
- Virtual guides

Virtual guides are not part of the final harness product. They are collected in a container under the harness assembly and they help users to create channel edges faster and more comfortably.

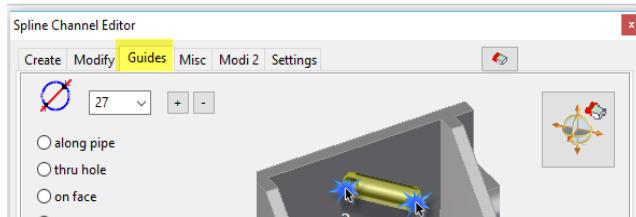
To route a channel edge through a guide:

1. If not already there, create a virtual guide using one of the functions in the **Guides** tab.



2. Start to create an edge with the  command and select the start point.
3. Click  and select the virtual guide; the edge will pass through the guide.
4. Continue specifying next points , or click further guides  or click OK  to finish.

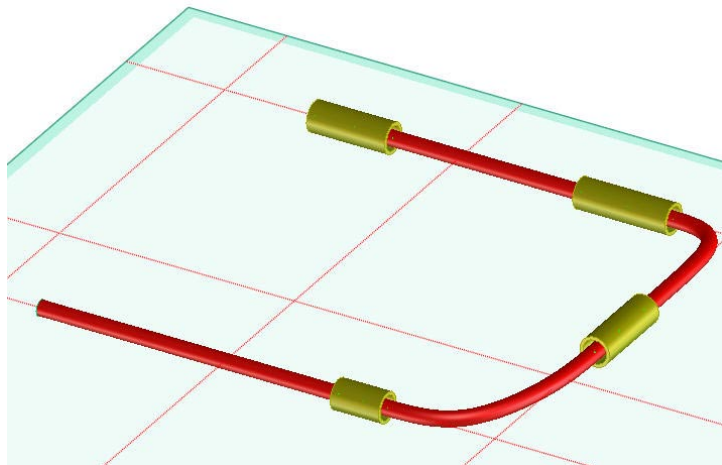

Cabling automatically detects the shortest way from the last segment point to the guide. In certain cases

the opposite direction may be desired. Reverse routing direction by clicking REVERSE



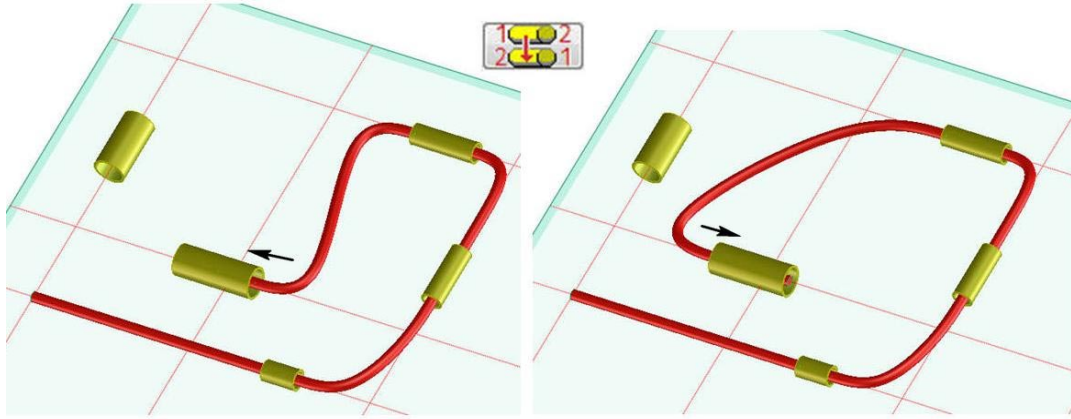

Straight lines—Creates a straight segment by adding several points on a linear path.

Many times the channel edge should run in a straight line. Instead of selecting several points on a linear path, you can use the 'Straight Line' option and select only the start and end point. Cabling will create intermediate points and tangent directions to keep the channel segment straight.

To create channel as straight lines,

1. Click .

2. Specify start and end points.

See the following example:

1. Click .



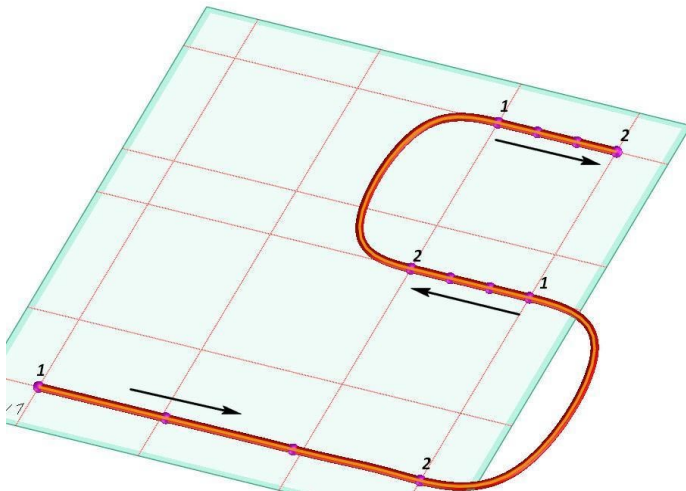

2. Specify start and end points (Segment '1' will appear).

3. Specify next points (Segment '2' will appear).

4. Click Ok  to finish.



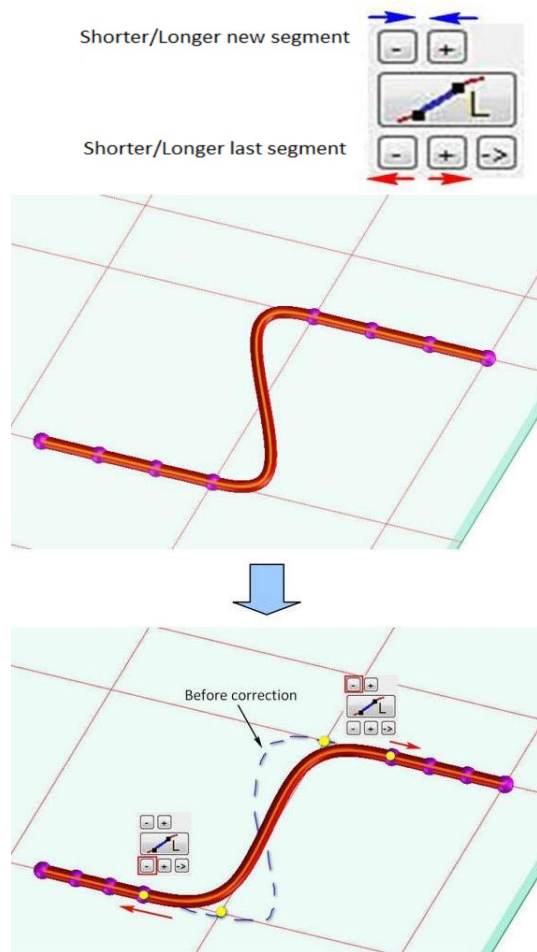

Small buttons  and  under and above  help to correct the shape of the connection between two subsequent straight line segments.

- **Lower** buttons move last point of the last segment;  – back and  – forth.
- **Upper** buttons move first point of the new segment;  – forth and  – back.



With the  button, you can fix the direction of the straight line segment. When a direction is set, no matter how the end point is selected, the straight segment will run in the selected direction.

To create segment in a given direction,

1. Click  and set a direction for the coming straight line segment.
2. Click  and specify two points – for the test – make sure to select the end point off the direction line.

See below examples:

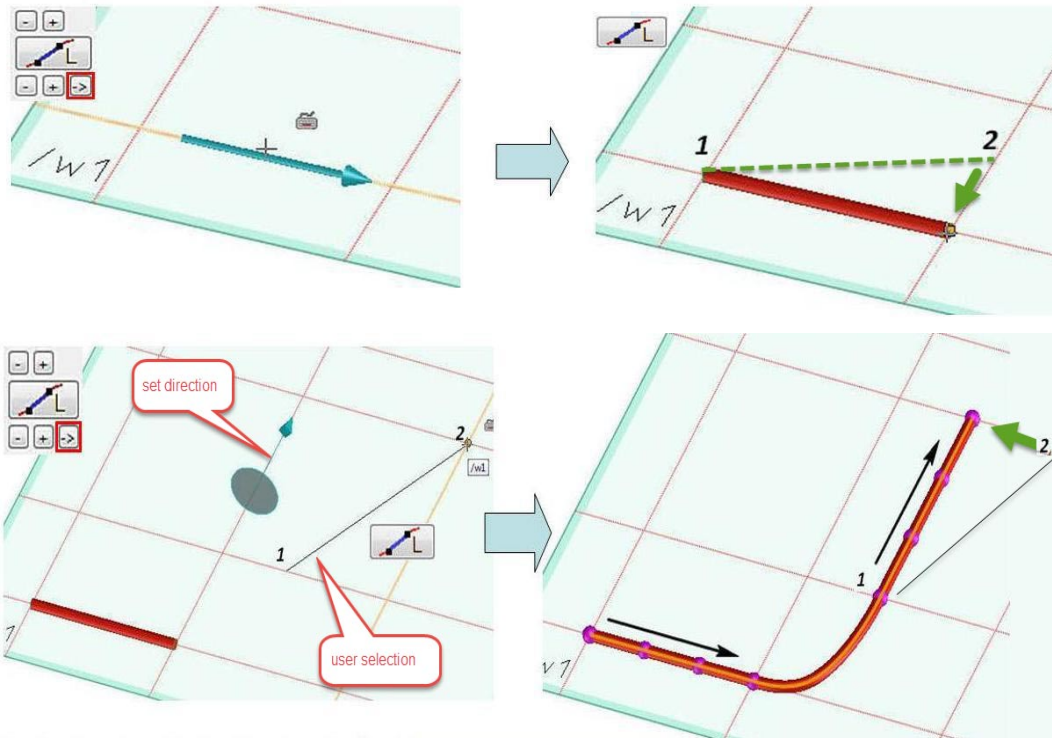

The **Create** tab has some further functions:

—Shows/hides interpolation points of the channel.

—Shows/hides the 3D CoPilot.

Show solids check box—Toggles solid creation behavior when new segments are created.



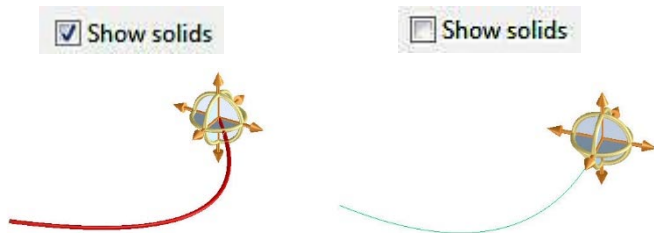

Intelligent—When the **Intelligent** check box is set, you do not have to explicitly select “Point”, “Split”, “Connector”, or “Guide” options while routing the edge. Cabling will detect the object under the selected point and automatically select the appropriate action.

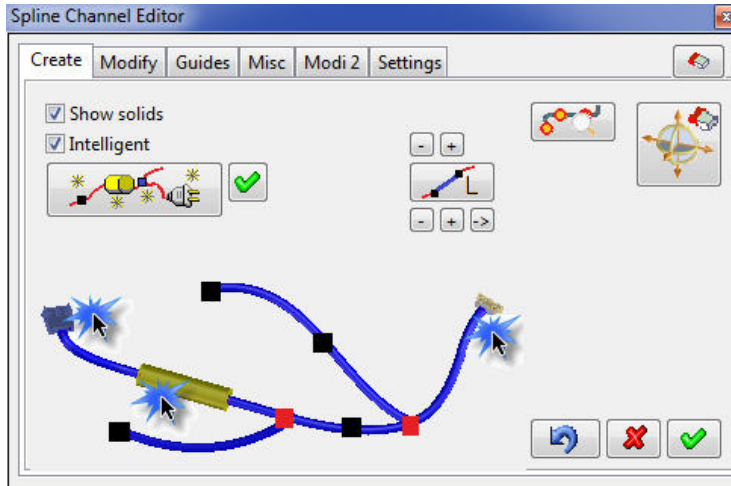

Modify Tab

The **Modify** tab of the **Spline Channel Editor** contains commands for modifying channel edges.

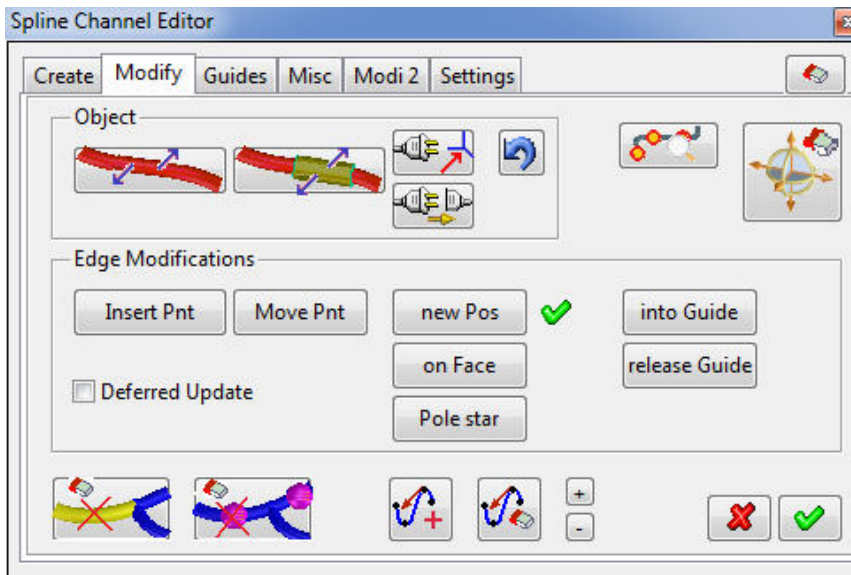

Channel edges can be modified by different methods.

- Directly

With the button  select the edge to modify. Edge interpolation points will be visible on the selected edge. Move, delete and insert points to modify the channel edge.

- Indirectly by moving its guides

- a. Click  and select guide. The **Position** dialog box appears.
- b. Move guide using **3D CoPilot** or commands from the **Position** dialog box
- c. The channel edge will automatically follow the guide

- Indirectly by moving its connectors. Here we have two different methods.

To move a connector dynamically:

- a. Click  and select a connector. The **Position** dialog box appears.
- b. Move connector using the **3D CoPilot** or commands from the **Position** dialog box.

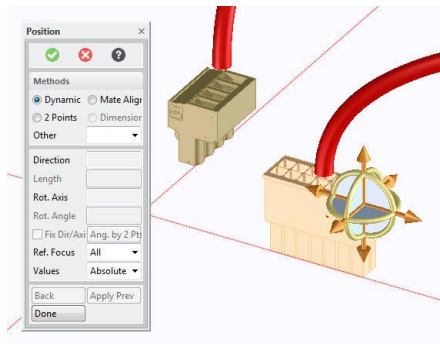

To move a connector to its snap-in partner:

- a. Click  and select the connector which you want connect with its snap-in partner.
- b. Select the snapping partner. Connector will automatically snap to its partner.

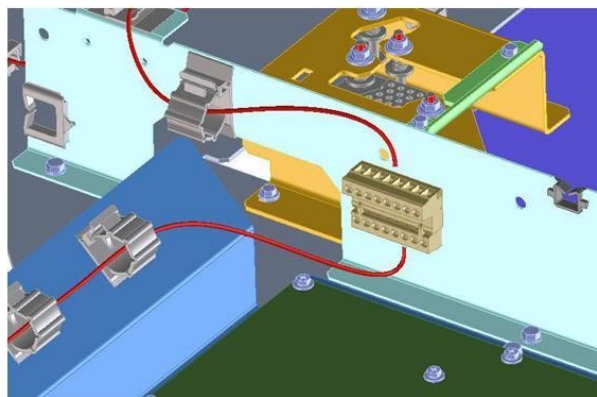
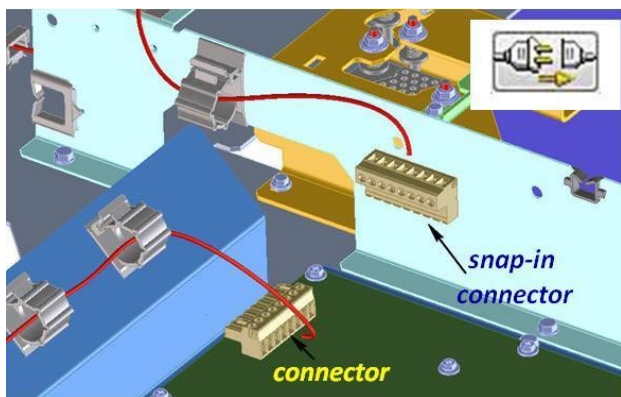

Edge Modification group placed commands for working with channels:

- **Insert Pnt**—Insert interpolation point to channel edge.

To insert a point to a channel edge,

- a. Click  and select a channel edge.
- b. Then click **Insert point** and specify a point on the selected channel edge.
- c. A new point will be inserted into the edge and it is immediately ready to move. You can select a new destination point and the inserted point will be moved right away.

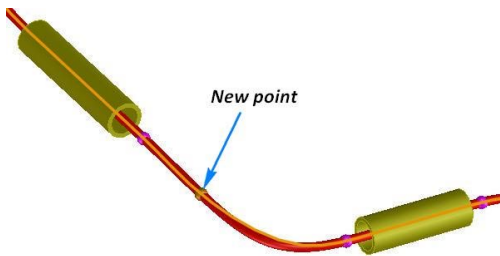

- **Move Pnt**—Move interpolation point.

To move a point,

- Click  and select a channel edge - existing points will be visible.
- Click **Move point** and select a point.
- According to the selected mode move the point to the new position.

Note:  indicates the current 'Move point' mode.

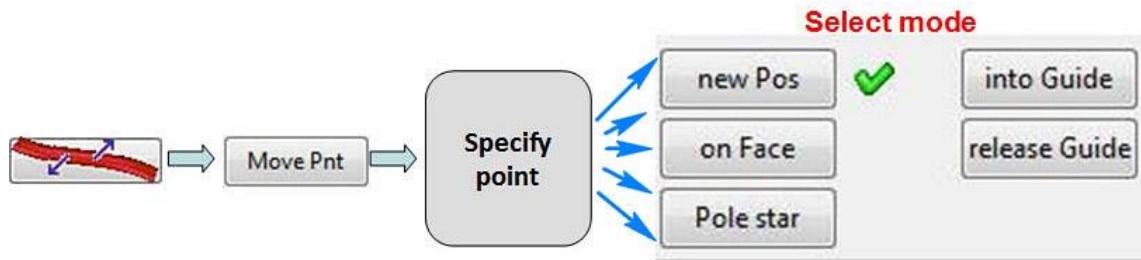

Modification modes:

- **New Pos**—Moves selected point with object snap. Selected point cannot be moved in the air. This is the default mode for Cabling.

To move a point to a new position,

- Click  and select a channel edge; existing points will be visible.
- Click **Move Point** and specify a point.
- Select **New Pos** and specify a point for the new position.

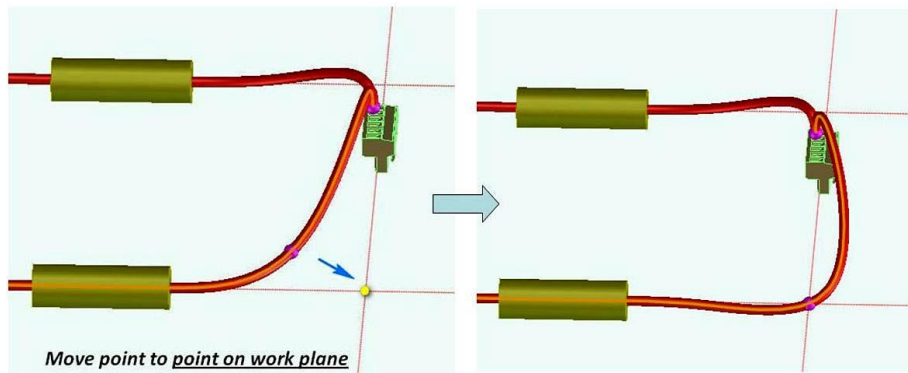

- **on Face**—Move interpolation point onto a face.

When a point on a face is selected, Cabling will automatically shift the selected point in the face normal so that the channel will not 'sit' in the face but 'lay' on the face.

To move point on face,

- a. Click  and select channel edge; existing points will be visible.
- b. Click **Move Point** and specify a point.
- c. Select **on Face** and specify a face.

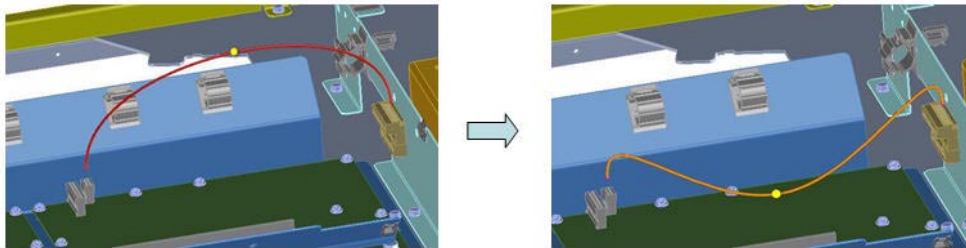
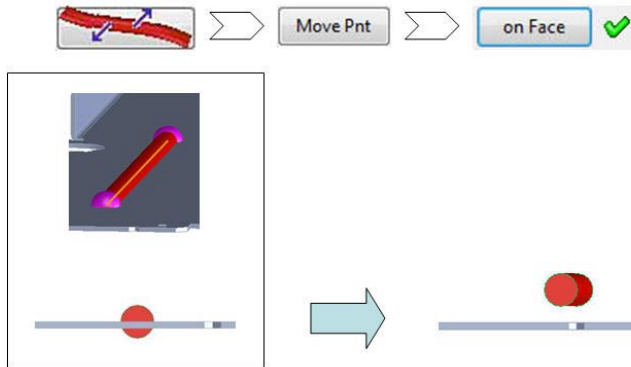

- **3D CoPilot**—To move selected point dynamically in the 'air'.

Many times the channel must follow a path in the 'air'. Since it is not possible to select a point in the air, user must use the **3D CoPilot** to drag a point to the desired position.

To move a point using the **3D CoPilot**,

- a. Click  and select channel edge; existing points will be visible.
- b. Click **Move Point** and specify a point.
- c. Click **3D CoPilot**; the 3D CoPilot appears.
- d. Move the point to desired position using the CoPilot.

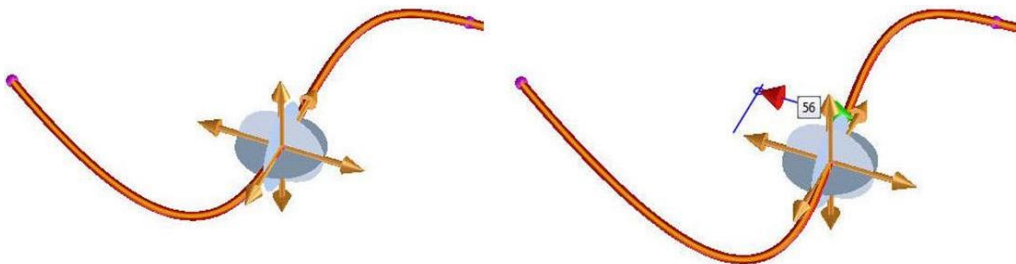

- **into Guide**—Drags part of a channel edge into a guide.
 - a. Click **into Guide**.

- b. Specify a point on a channel edge. The edge at the selected point will be dragged into the guide.

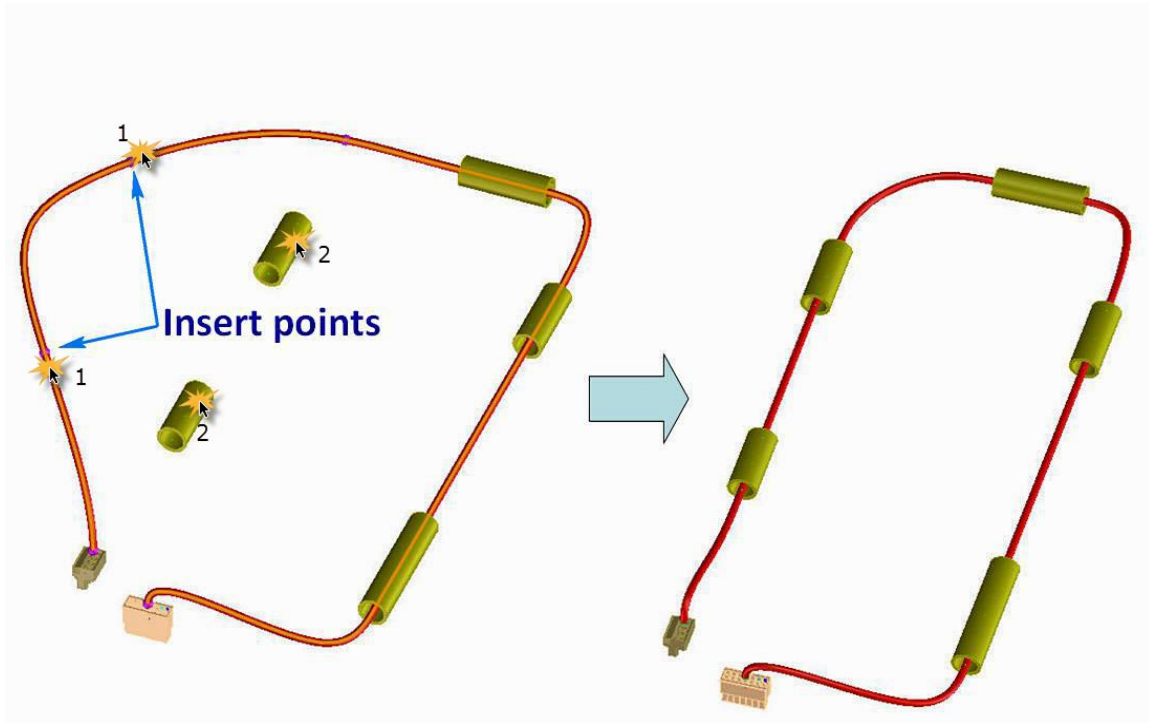

- **release Guide**—Releases channel edge out of a guide.

Click **release Guide** and select guide. All channel edges in the guide will be released.

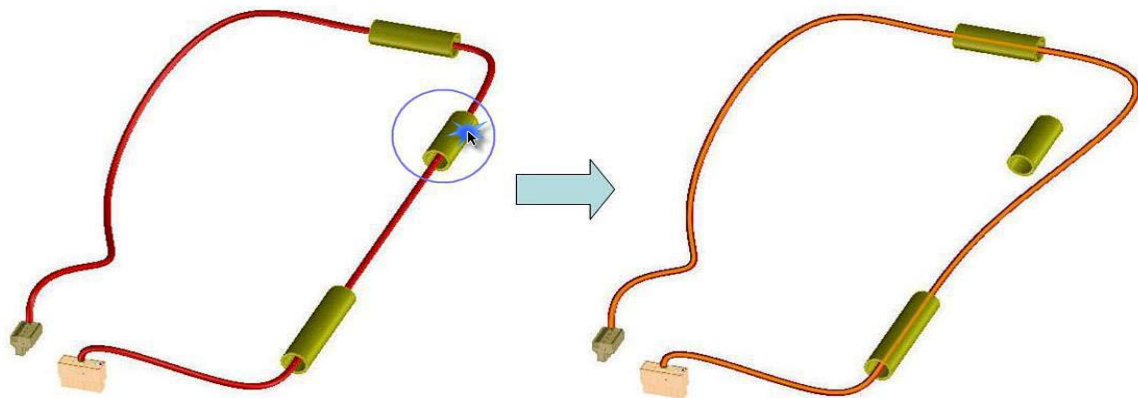

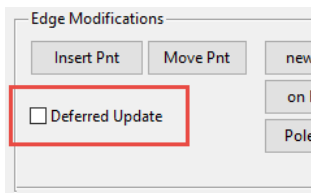

- **Deferred Update:**





Each time you make a modification, Cabling will automatically update the solid representation of this channel edge. In certain cases, when you want to make several subsequent changes to one edge,

it can be preferable to suppress the solids update until all modifications are done. Set the **Deferred Update** check box to suppress the update of solids. Click **Update Now** when update should be done.

At the bottom of the **Modify** tab there are some more functions:

- —Delete complete channel segment.
- —Delete interpolation point of a segment.
- —Assign tangency in an interpolation point.

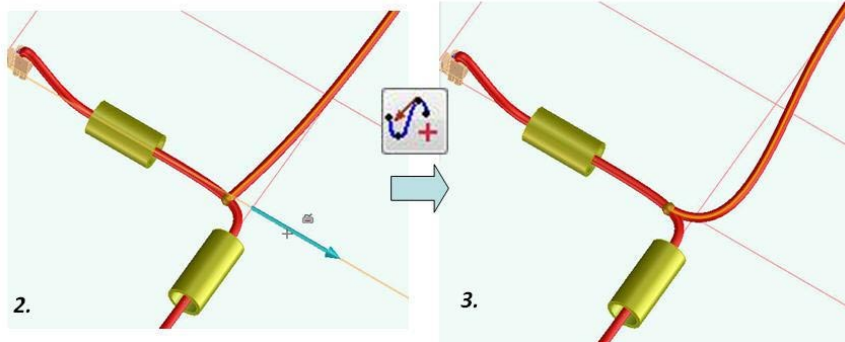
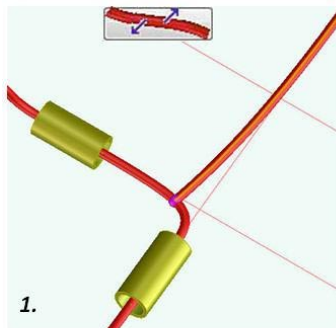

To assign tangency,

- a. Click  and select channel segment; existing points will be visible.
- b. Click  and specify point.
- c. Define direction of tangent vector.



- —Delete tangency in an interpolation point.

To delete tangency,

- a. Click  and select channel segment; existing points will be visible.
- b. Click  and specify point. Tangency will be deleted.

The '+' and '-' buttons increase and decrease tangent weights, respectively.



To modify tangent weights select interpolation point with assigned tangency and click the '+' or '-' buttons.

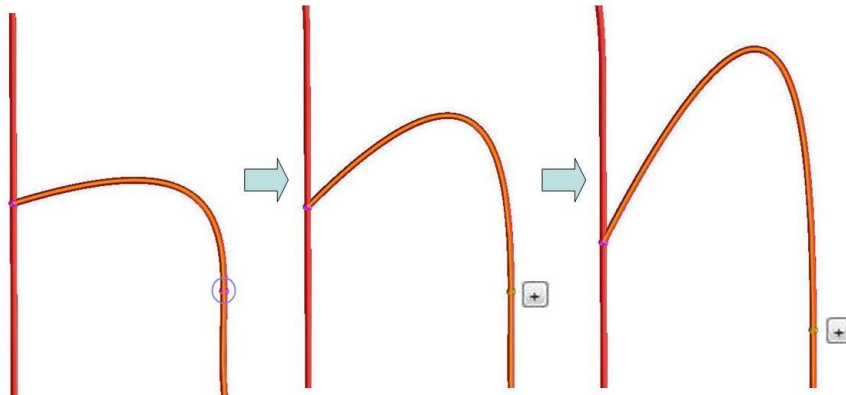

Guides Tab

The **Guides** tab of the **Spline Channel Editor** offers commands for creation and modification of virtual guides. Virtual guides are not necessarily physical objects. They do not have to exist in the final harness.

They are simply helping users to route channel edges faster, better and more comfortably. Virtual guides are kept in a container under the harness assembly. Even though channel edges are not associative to their virtual guides and they can be deleted after usage, it is better to keep them for further channel modifications.

Which diameter should I choose for my virtual guide?

At the time of channel creation, we do not know which wires will be inserted in this particular channel segment in the future. That's why it is not possible to determine the guide diameter.

Cablings only checks the center point of the guide's cylindrical face against channel edge interpolation points to decide if a channel edge is in the fixture or not. It does not mind if the solid channel part is larger than the guide's cylinder or not. For this reason, you can simply select any diameter for the virtual guide. For better visualization it is recommended that you select a slightly bigger diameter than the solid size of the channel.

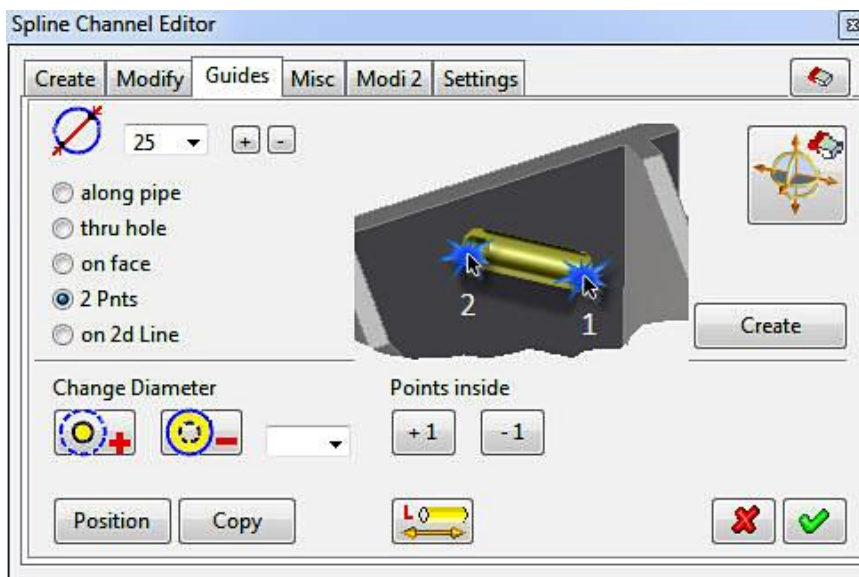

Choose the diameter of the guide from drop down list or enter it manually.



Small buttons **+** and **-** can increase or reduce diameter of the last created guide.

There are five methods to create virtual guides in the **Spline Channel Editor**.

Note: To start the guide creation either select the option or click **Create**.

- **along pipe**—Creates guides along cylindrical faces.
 - a. Specify length of guide—Enter value or select from the drop down list 'L =...'
 - b. Select point on a cylindrical surface. Guide is created at the selection point.
 - c. If necessary, rotate guide around cylinder axis using rotation buttons '+1, ±10'.

Minimum rotation step is '1', maximum is - '10'.

Use '-' for clockwise and '+' for counterclockwise rotation. The diameter of the guide can also be modified with the '+' and '-' buttons next to diameter icon.

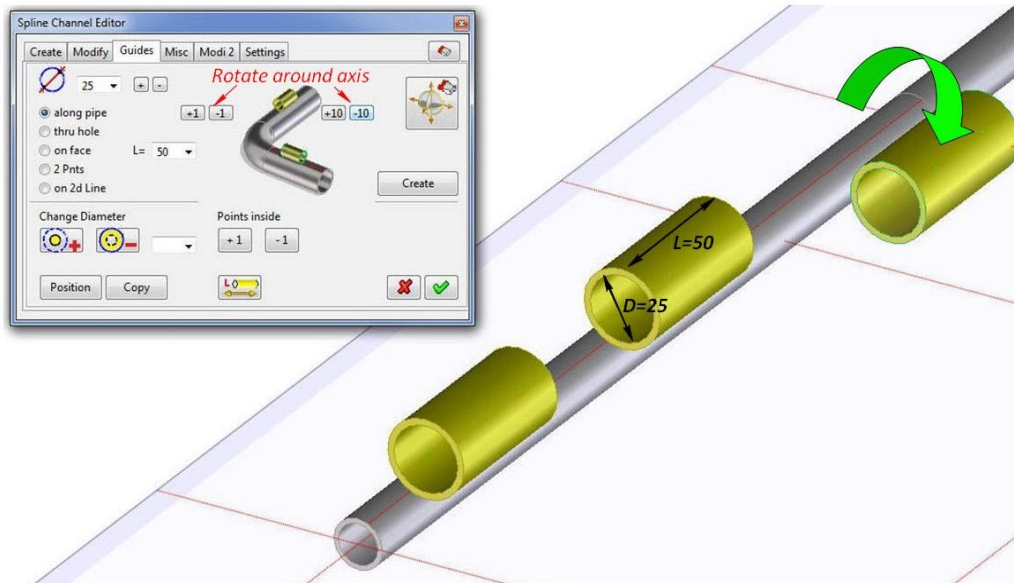

- **thru hole**—Creates guides through holes in parts.

- a. Specify length of guide—Enter value or select from the drop down list 'L ='
- b. Select radial surface of a hole. Guide is created along the cylinder axis.

The diameter of the guide can also be modified with the '+' and '-' buttons next to diameter icon.

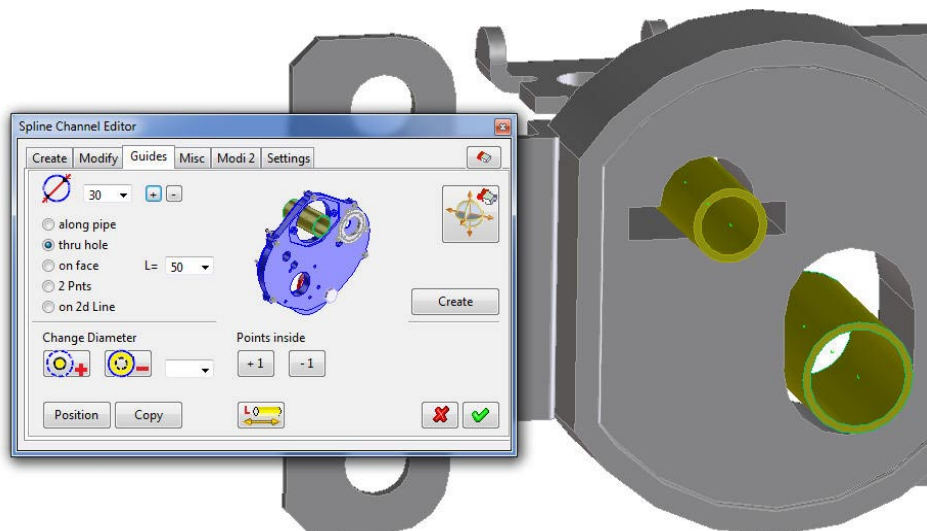

- **on face**—Creates guides on faces.

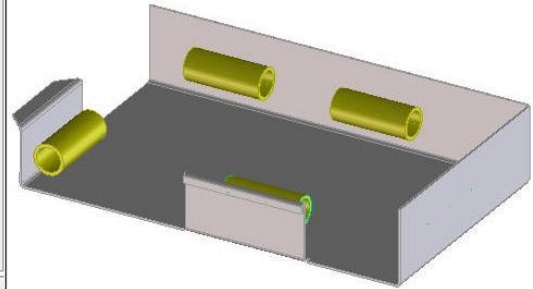
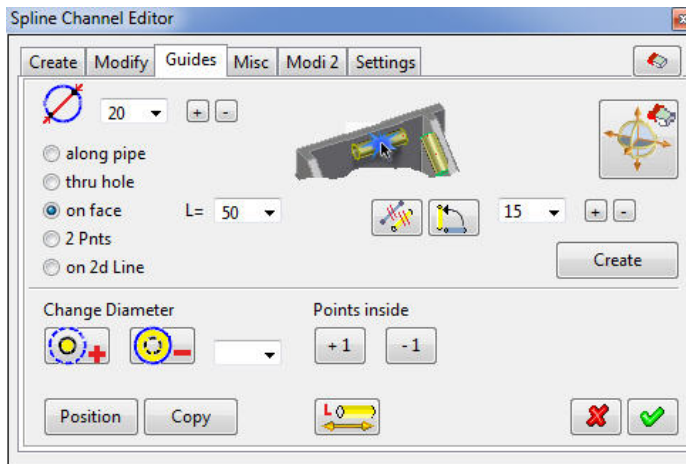



- Specify length of guide—Enter value or select from the drop down list 'L ='
- Select start and end point of the guide on the same face. Guide will be created.



You can rotate the guide incrementally or parallel to a selected direction.

To rotate the guide parallel to a 2D or 3D edge:

- Click  and select edge. The guide will be rotated parallel to the defined edge.

To rotate the guide incrementally by a specified angle:

- Select value of rotation angle in the drop-down list  at the right side of tab.
- Click . The guide rotates at the specified angle.

The length of the guide can further be modified using buttons  and  next to angle values.



The diameter of the guide can also be modified with the '+' and '-' buttons next to diameter icon.

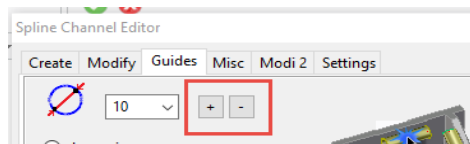

- **2 Pnts**—Creates guides by specifying start and end points.

To create guide from point to point specify start point and end point. After the guide is created, a 3D CoPilot will be visible at the new created guide for further positioning. The diameter of the guide can also be modified with the '+' and '-' buttons.

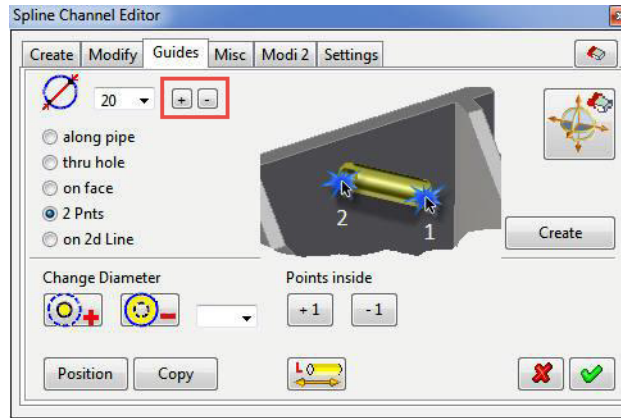

- **on 2d Line**—Creates guides on 2D lines.
 - Specify a 2D line. The guide will be created along the selected line on the workplane.

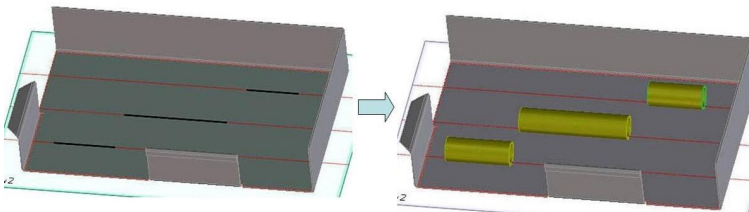
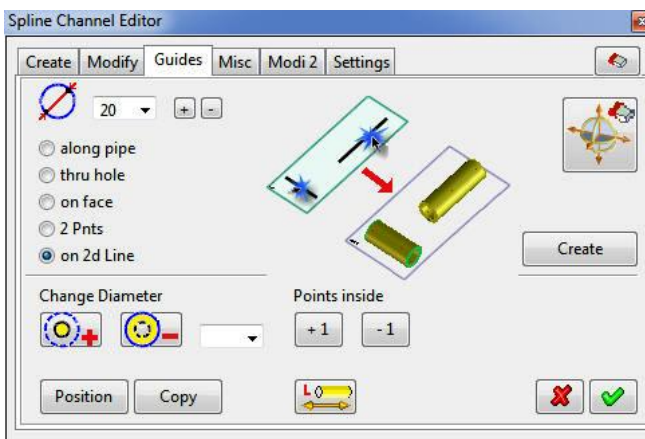

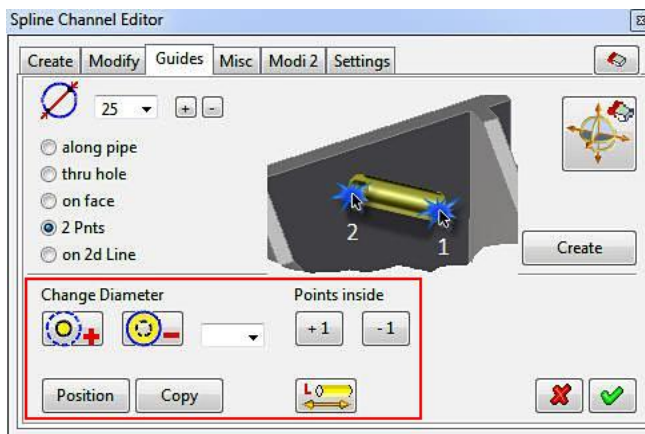

The diameter of the guide can also be modified with the '+' and '-' buttons.

On the bottom of the **Guides** tab, you will find commands for guide modifications:



- **Change Diameter**—Modifies diameter of the guide.

- Click  if you need to increase diameter and then select the guide.
- Click  if you need to reduce diameter and then select the guide. Modification step is '5 mm'.
- For a specific diameter you can set a value in the text field or select from the drop-down list, and then select the guide.

Note: Diameter of the guide is only a visual parameter. Changing diameter of guides do not have any impact on the channel.

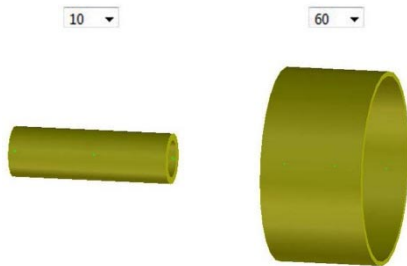

- **Points inside**—Modifies number of passing points inside guides.

Number of 'passing points' of a guide has a direct influence on path straightness. Guides are created initially with three passing points inside. This is the minimum number. But if a guide is very long then three points will not be enough for a fairly straight routing. The edge may 'swing' in the guide and it has no impact on functionality this will visually not look nice.

In this case users can add additional points to increase straightness. (You can also reduce number of passing points but keep in mind that three is the minimum number)

- To add additional points into a guide, click button '+1' and select the guide. Number of points will be increased and all channel edges inside the guide will be automatically updated.
- To reduce number of passing points, click button '-1' and select the guide. Number of points will be reduced and all channel edges inside the guide will be automatically updated.

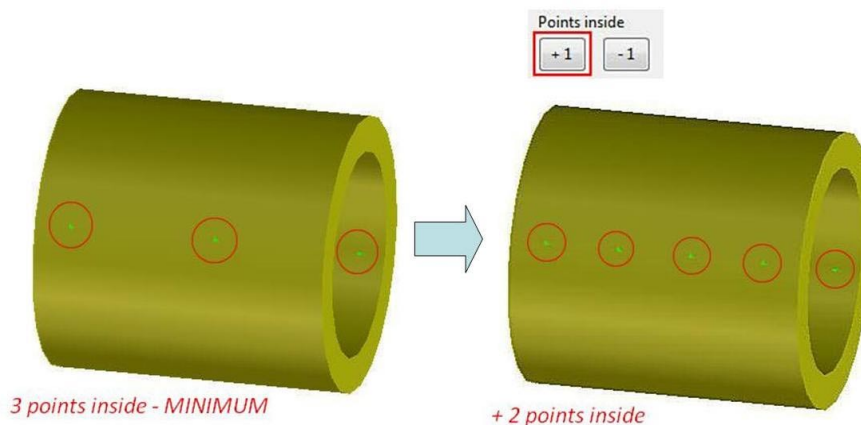

- —Changes lengths of guides.

- Click  and select a guide. A CoPilot drag arrow will appear at the closer end to the selected point.
- Pull the arrow to change the guide length. You may also enter numerical values in the text field.

Note: Changing length of guides have a direct influence on the channel shape.

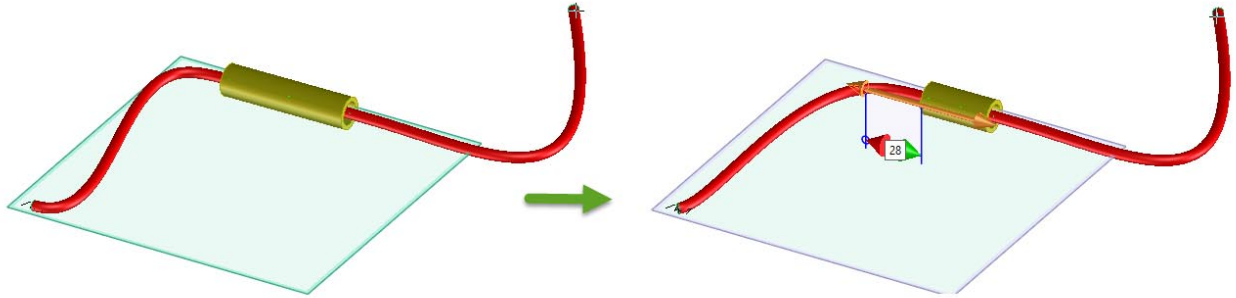

- **Position**—Moves guides dynamically.

1. Click and the **Position** dialog box opens.
2. Move guide using the **Position** dialog box.

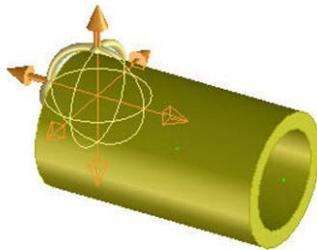
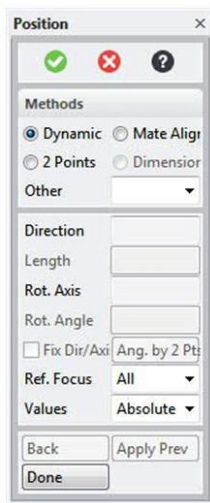

Note: This is a pure positioning command for the guide itself. This command is intended to be used to position 'empty' guides. It will not modify or update any channel edges inside this guide. If you want to move a 'full' guide together with its edges, use the **Guide Modify** command on the **Modify** tab.

- **Copy**—Creates copies of guides.

1. Click and select guide which you want copy.
2. A copy of the guide will appear next to the guide and the **Position** dialog box opens up for further positioning of the copied object.

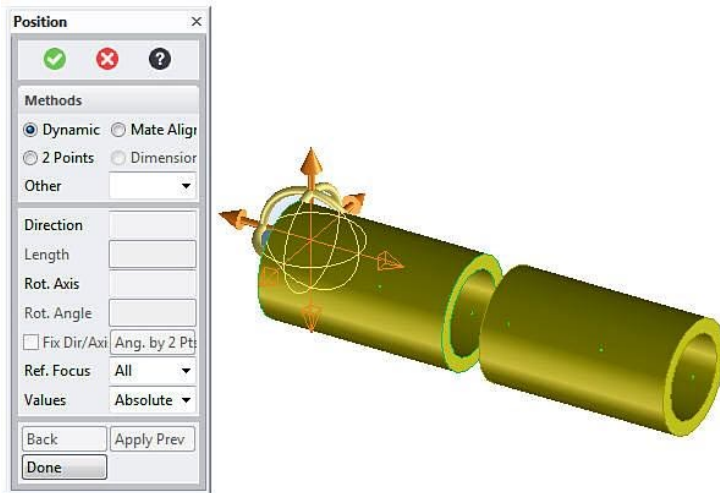

Misc Tab

The **Misc** tab of the **Spline Channel Editor** contains miscellaneous commands.

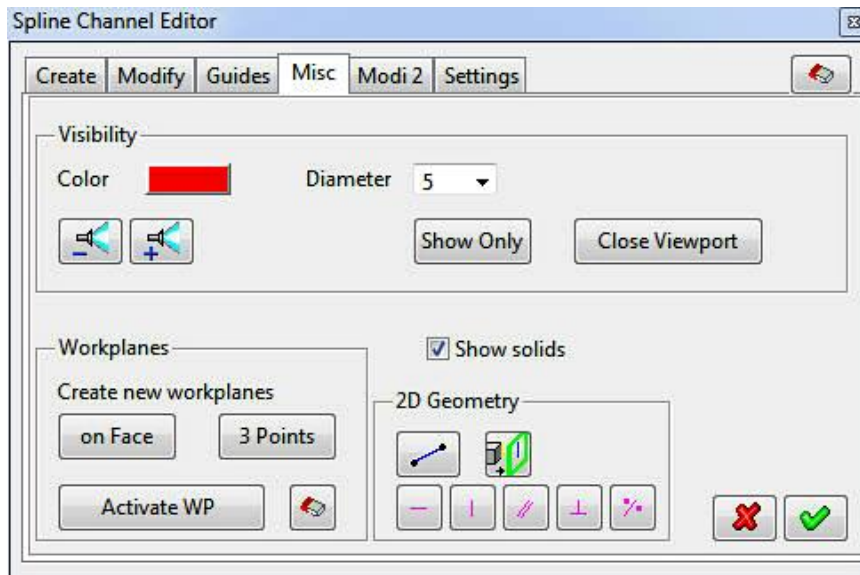

At the top of the **Misc** tab, the **Visibility** group is placed.

- **Color**—Defines color for the solid representation of the channel.
In Cabling solid representation for channel is red by default
 1. Click '**Color**' in the **Visibility** group.
 2. The **Color Selector** dialog box opens. Select desired color from color palette.

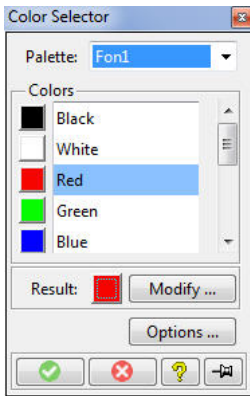

- **Diameter**—Defines diameter of solid representation.

To change diameter of solid parts, select value for diameter from drop down list or enter your own value. Diameter of all existing solid parts will be updated.

- **Hide/Show**  are placed here for convenience only to show and hide 3d objects.

- **Show Only**—Shows only selected object together with the channel in viewport.

Unlike the standard Creo command 'Show only in viewport', this command will always show the channel together with the selected object in a new viewport.

- Click **Show Only** and select an object in the viewport. A new viewport window will open and only the selected object and the channel part will be shown.

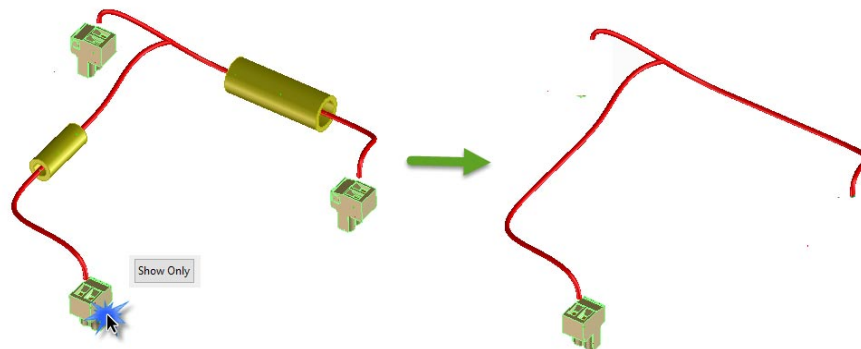

- **Close viewport**—Closes the viewport which was opened with the 'Show Only' command.

In the left lower corner of the **Misc** tab, you will find commands to work with **Workplanes**. They are here only for convenience and allow you to work with some basic workplane functions without leaving the Spline Editor Menu.

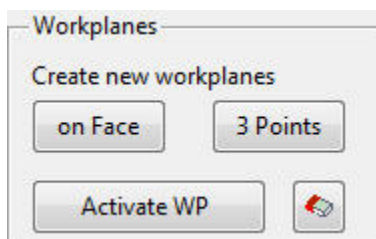

- **on Face**—Creates a workplane on the selected face.



Click **on Face** and select any face of a 3D object. A new workplane will be created on the selected face.



- **3 points**—Creates a workplane through three points.
Click **3 Points** and specify 3 points to create a workplane. A new workplane passing through these points will be created in the work space.
- **Activate WP**—Activates a workplane.
To make a workplane active click **Activate WP** and select a workplane.
-  deletes a 3d object.
To delete 3D object click button and select an object.

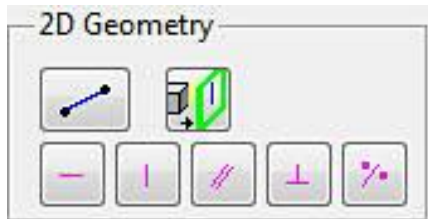

Next group of the **Misc** tab is **2D Geometry**—it contains commands to create 2D geometry and construction lines on workplanes.

Note: You need to have an active workplane to create 2D geometry.



- To draw a 2D geometry by **Point to Point**,
 1. Click  button in the **2D Geometry** group.
 2. Click a point on the workplane for the start location of the line.
 3. Click a point on the workplane for the end location of the line.
- To project the geometry of 3D edge onto the active workplane as construction geometry,
 1. Click  in the **2D Geometry** group.
 2. Select 3D edge of part.

You can create vertical, horizontal, and other construction lines with the commands from the **2D Geometry** group.
- To draw a horizontal construction line,
 1. Click  in the **2D Geometry** group.
 2. Select a point on the workplane to draw a horizontal construction line.
- To draw a vertical construction line,
 1. Click  in the **2D Geometry** group.
 2. Select a point on the workplane to draw a vertical construction line.
- To draw a parallel construction line,
 1. Click  in the **2D Geometry** group.
 2. Select the line or any 2D element to which you want to draw a parallel construction line or follow the prompt and enter one or more offsets first.
 3. If a reference line is selected first without giving any offsets, move the cursor away and the 2D CoPilot shows the distance from the selected line. You can also type a distance and press ENTER to create the parallel line.

- To draw a perpendicular construction line,
 1. Click  in the **2D Geometry** group.
 2. Click the existing line to draw from perpendicularly.
 3. Click a point of the new construction line.
- To draw a construction bisector,
 1. Click  in the **2D Geometry** group.
 2. Click any point. The 2D CoPilot helps you find a center point, midpoint, vertex, or an intersection point on the existing geometry.
 3. Click the second point. A bisector line is drawn at the midpoint (assuming a fraction value of 0.5) and perpendicular to the two points you clicked.

Modi 2 Tab

The **Modi 2** tab of **Spline Channel Editor** contains two additional commands to modify channel segments.

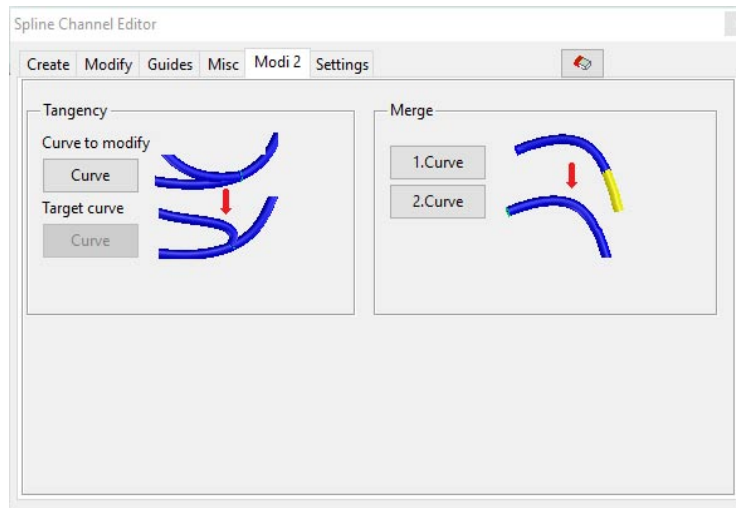

- **Tangency**—connects selected segment tangentially to another edge.
Note: Both edges must share a common point.

To change tangent at end point,

1. Click the first **Curve** button and select segment to be modified.
2. Click the second **Curve** button and select the segment close to the desired end point to be tangent to.

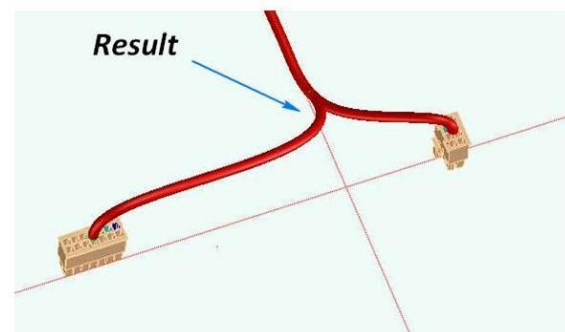
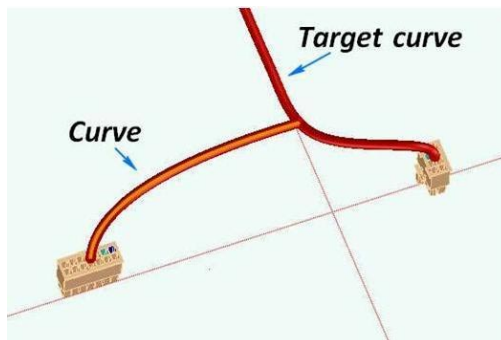

- **Merge**—merges two segments into one single curve.

To merge two curves,

1. Click **1.Curve** and select the first curve.
2. Click **2.Curve** and select the second curve.

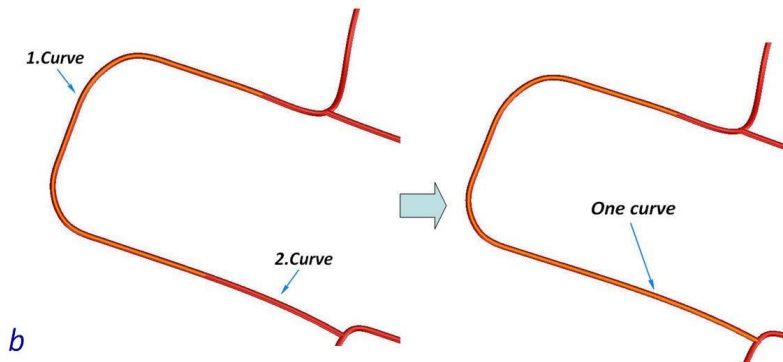

Note: This command can also be used to connect two segments with a gap in between. The gap will be automatically closed.



Settings Tab

The **Settings** tab of the **Spline Channel Editor** contains commands to set search paths for channel edges when a virtual guide is moved.

You can have channel edges from different harness assemblies in one virtual channel. If you move the guide, Cabling must determine which channel edges are inside the virtual guide. To do this, Cabling must check edges of all channel parts in all Cabling harnesses found in the work space.

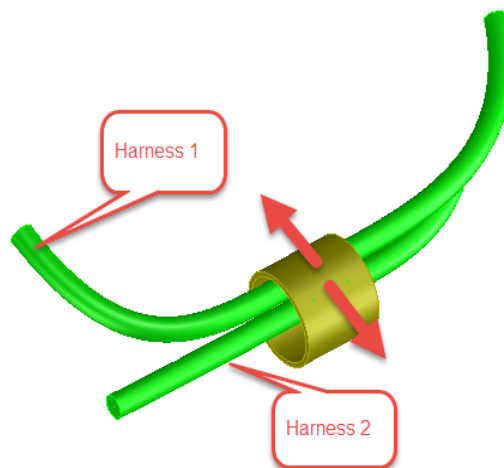

If you have thousands of parts in your work space, this may take some time to detect cabling harnesses. The default is to search from the top. Here you can limit the search path to accelerate the harness search.

©2016 PTC Inc. The information contained herein is provided for informational use and is subject to change without notice. The only warranties for PTC products and services are set forth in the express warranty statements accompanying such products and services and nothing herein should be construed as constituting an additional warranty. PTC shall not be liable for technical or editorial errors or omissions contained herein. Important Copyright, Trademark, Patent, and Licensing Information: See the About Box, or copyright notice, of your PTC software.